

**Company Profile Application Design as Promotional Media Using
Laravel
(Case Study in Creative Design Field)**

**Hanny Nurhanifah¹, Rohmat Nur Ibrahim², Toni Kusnandar³, Alia Tri
Utami⁴**

^{1,2,3,4} STMIK Mardira Indonesia, Bandung

Email: nhf.hanny@gmail.com¹, rohmat@stmik-mi.ac.id², toni@stmik-mi.ac.id³,
alia@stmik-mi.ac.id⁴

Abstract

Creative Design, a design agency specializing in creative services such as graphic design, encounters intense competition in the expanding design market. Presently, corporations depend on social media as a means of promotion. However, the outcomes could be more optimal. Moreover, Creative Design encounters challenges in engaging with prospective customers, impeding the company's capacity to establish robust connections with potential clients. In order to address these problems, it is imperative to create and construct a contemporary, engaging, and appealing company profile application utilizing Laravel as the development framework. By utilizing Laravel as the underlying framework for constructing the company profile application, Creative Design can enhance the program's performance, bolster its security measures, and facilitate future expansion of its functionality. The app will allow Creative Design to effectively showcase its portfolio, outline its design services, and furnish clients with the company's contact information in an immersive and dynamic manner. This project aims to develop a corporate profile application utilizing Laravel as a promotional instrument for Creative Design. By utilizing this program, Creative Design aims to enhance its online presence, attract prospective consumers, and improve user experience. This study's results can significantly enhance a company's visibility, enhance company reporting, foster more substantial engagement with potential consumers, and enhance presentations.

Keywords: *Application Design, Company Profile, Design, Promotion, Laravel*

Introduction

The advent of information technology and the internet has profoundly influenced the methods by which organizations advertise and market their products or services. Mobile applications have emerged as very effective tools in the digital age for companies to extend their reach and enhance their visibility in the online realm. Firm profile applications serve as a crucial method for showcasing a firm, illustrating its corporate identity, and emphasizing the services or goods it provides. Creative Design, a company specializing in creative design, particularly graphic design, must leverage these technical advancements to enhance its visibility and competitiveness in an ever more cutthroat market. (Gibran, Dewi & Hadinata, 2024; Prasetyo, Utami & Laksana, 2024; Samosir, Prasetyo, Lumbantobing, Naibaho & Situmorang, 2021)

Creative Design encounters difficulties in effectively promoting itself in the digital realm. Presently, the company's digital presence is confined to social media platforms and a basic website, so restricting its capacity to efficiently allure prospective clients and broaden its market reach. Having a robust company profile application is essential in the visually-oriented and innovative design sector. This application will showcase a portfolio of Creative Design's work and offer an interactive experience to users, enhancing their interest and trust in the services provided. Hence, it is crucial to create and construct contemporary, interactive, and captivating company profile applications utilizing the appropriate technologies. (Amalia, Gumilar, Utama & Dewi, 2023; Amini, Rahmani, Abedi, Hosseini, Amini & Amini, 2021; Kambivi, Junirianto & Fadhliyah, 2020)

The decision to use Laravel, a widely-used PHP framework, was made for the development of this application. Laravel provides several benefits, including rapid execution speed, a modular architecture, and simplicity in web application development. Leveraging Laravel, Creative Design can boost the performance, security, and flexibility of its corporate profile applications, allowing for future expansion of features. In addition, Laravel offers a multitude of features and tools that facilitate the development of customized applications to meet the specific requirements of a firm.

Therefore, it is anticipated that utilizing Laravel will offer a productive and streamlined approach in creating the necessary company profile application for Creative Design.

Within this particular framework, the objective of this study is to create and construct the Creative Design company profile application, with the intention of utilizing it as a powerful tool for promotion. The primary goals of this research are to ascertain the requirements and specifications of a company profile application that aligns with Creative Design, create an appealing and user-friendly user interface (UI), construct a company profile application using the Laravel framework, conduct thorough testing to ensure its functionality and security, and evaluate the effects of application usage on Creative Design's visibility and competitiveness in the market. This development process will encompass multiple stages, commencing with needs analysis, followed by design, development, testing, and concluding with application implementation. (Raihan & Negara, 2023; Nurninawati, Effendy & Rianputra, 2023; Marchiato & Wella, 2024)

The initial phase of the development process is needs analysis, which entails gathering data and information pertaining to Creative Design's requirements for the corporate profile application. The employed methodologies encompassed conducting interviews with both management and staff, in addition to administering surveys to customers and prospective customers, with the aim of comprehending their expectations for the application. The data acquired during this phase will serve as the foundation for developing the user interface (UI) and application architecture. UI design mostly emphasizes the visual appeal and user-friendliness of a system, whereas application architecture design primarily focuses on the organization and expandability of the system. (Zabidi, Ali, Yassin, Tahir & Rizman, 2022; Wini, Siregar & Simargolang, 2024; Usanto, Nurlaela, Sopian & Alfiah, 2023)

The subsequent phase is development, which entails executing the design that has been established utilizing the Laravel framework. The development process follows an iterative approach, where the focus is on implementing essential functionality initially and subsequently including

supplementary features as required. Once the application has been constructed, testing is conducted to verify that the application operates in accordance with the required standards. Testing includes the evaluation of the application's functionality, security, and performance. The last phase is implementation, which entails incorporating the application into the Creative Design system and providing training to users to ensure proficient use of the tool.

By utilizing Laravel to develop a company profile application, Creative Design aims to enhance its presence and competitive edge in the market. This application will serve as a very efficient promotional platform to demonstrate the exceptional quality and excellence of services provided by Creative Design. In addition, this application is anticipated to enhance customer engagement and streamline the process of accessing information about the available services for prospective clients. Furthermore, it is anticipated that this firm profile application will serve as a valuable instrument in enhancing Creative Design's operating efficiency. This program facilitates the promotion and communication process with clients by providing a planned and efficient approach. Furthermore, this application enables Creative Design to gather data and receive feedback from consumers, so facilitating the enhancement of their services. (Rabiah, Lindawati & Sarjana, 2022; Tiana & Nopriandi, 2023)

This research offers numerous advantages, both in terms of enhancing creative design and advancing information technology in the realm of graphic design as a whole. The application built by Creative Design for the company profile can serve as a highly effective and efficient advertising tool. This application allows Creative Design to showcase their work portfolios, customer testimonials, and service-related information in a captivating and engaging manner. Anticipated outcomes include a rise in client base and the broadening of Creative Design's market reach. This research can serve as a reference for other graphic design organizations in the market who are interested in developing company profile applications. The aim of this research is to offer advise on how to design and construct efficient corporate profile applications using Laravel.

In addition, this research has the potential to contribute to the advancement of information technology, particularly in the utilization of Laravel as a framework for web application development. This case study aims to demonstrate the benefits and difficulties encountered when utilizing Laravel, while also offering practical strategies to overcome these obstacles. Therefore, it is anticipated that this research will have a beneficial impact on the graphic design sector and the overall advancement of information technology. (Christian & Erlina, 2021; Tjahyadi, 2021; Kumaladewi, Iqbal & Huda, 2022)

Ultimately, in the rapidly advancing digital age, the presence of a corporate profile application has become crucial for Creative Design to enhance its visibility and competitive edge in the market. Utilizing Laravel for the design and development of company profile applications is anticipated to offer a highly effective and efficient solution to fulfill Creative Design's promotional requirements. This application allows Creative Design to showcase its brand identity, work portfolio, and services in a visually appealing and engaging manner, with the aim of capturing the attention of potential consumers and expanding their customer base. Furthermore, it is anticipated that this research will have a beneficial impact on the graphic design sector and overall information technology advancement. Additionally, it can serve as a valuable resource for other organizations seeking to create comparable corporate profile applications.

Research Method

The research methodology employed in the development of the corporate profile application for Creative Design consists of a sequence of carefully planned steps aimed at ensuring a structured and efficient development process. The initial phase involves doing a needs analysis, during which data and information are acquired through interviews with management, corporate personnel, as well as surveys of customers and prospective customers. The objective of this study is to determine the unique requirements of Creative Design in terms of the features and functionalities

that should be included in their profile application. Additionally, it aims to comprehend the expectations and wants of potential users.

Once the needs analysis has been completed, the subsequent step is the design of the application. Design include aesthetically pleasing and user-friendly user interface (UI) design, as well as application architectural design that takes into account scalability and modularity. UI design is developed by using the concepts of pleasing visual appearance and user satisfaction, utilizing mockups and prototypes to evaluate its interactive functionality. Meanwhile, the application architecture design employs a methodology that facilitates incremental development and the seamless incorporation of new functionalities in the future.

The Laravel framework is utilized for application development due to its benefits in terms of development speed, security, and capability to manage intricate applications. The development process is conducted iteratively, starting with the construction of fundamental functionality and subsequently including additional features based on recognized priorities and needs from the analysis. After each stage of development, comprehensive testing is conducted to ensure that the application operates well in terms of functionality, security, and performance.

Once the development step is over, the application proceeds to an additional testing phase to guarantee its quality prior to implementation. The implementation process involves integrating the application into the Creative Design infrastructure and giving training to end users to ensure their successful utilization of the program. Continuous evaluation is conducted to assess the influence of the application on Creative Design's visibility and competitiveness in the market. Additionally, input obtained from the evaluation is utilized to make additional changes and advancements. Therefore, it is anticipated that this study methodology would generate a company profile application that not only fulfills the requirements of Creative Design but also delivers substantial benefits in enhancing the firm's service quality and operational efficiency.

Results and Discussion

Systems Analysis

1. Running System Analysis

Flowmap Company Profile as Promotional Media.

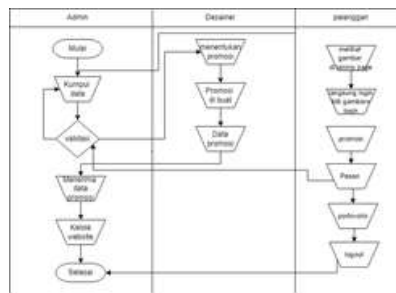

Figure 1. Flowmap Company Profile as Promotional Media

2. System Requirements Analysis

The objective of system requirements analysis is to facilitate the comprehension of the system's breakdown into distinct components, enabling the identification and assessment of issues about system development in alignment with current requirements, with the aspiration of selecting the optimal solution. The system or application developed from the current framework aims to enhance the online visibility of creative design, attract prospective clients, and improve the overall user experience during interactions with the business.

3. Use Case Diagrams

Goals	Admins and Designers can determine design promotions.
Pre-Condition	Admin and Designer have logged in.
Post-Condition	Successfully manage data and enter the promotion page.
Filed and Condition	Admin cannot change the type of promotion that the designer has determined.
Actors	Admin and Designer
Main Flow / Basic Path	<ol style="list-style-type: none"> 1. Admin logs in. 2. Admin manages designer data. 3. The system will display a promotion page.

2. Activity Diagram Landing page page

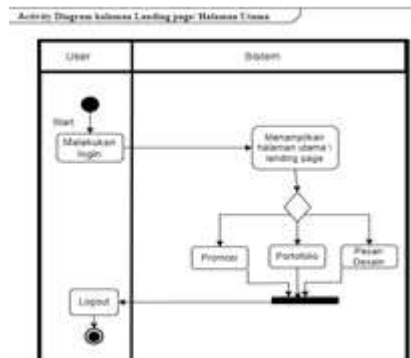

Figure 2. Landing page activity diagram

3. Promotion Sequence Diagram

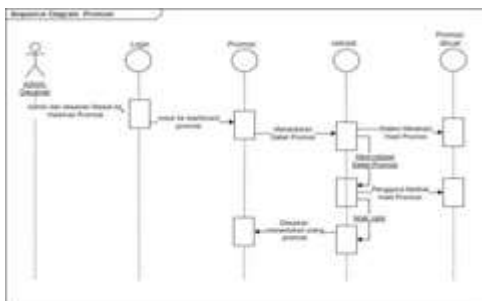

Figure 3. Promotion Sequence Diagram

4. Database Design Database Design



Figure 4. Database Design Database Design

5. Table Structure Design

The following is the table structure created for the Creative Design system:

Table Name : content_promo

Primary Key : id

Field	Type Data	Size
id	Bigint	20
promo code	Varchar	255
promotion name	Varchar	255
promotion definition	Varchar	255
price	Varchar	255
discount	Varchar	255
picture	Varchar	255
period	Varchar	255

6. UI Design From Home



Figure 5. UI Design From Home

System Implementation

The system implementation stage involves the process of defining an application system in a manner that prepares it for operation. This entails the integration of the application with Creative Design's comprehensive infrastructure, encompassing server setup and other technical

configurations. Furthermore, the deployment process encompasses providing training to end users to assure their proficiency in using the application. Continuous evaluation is conducted to assess the influence of the application on Creative Design's visibility and competitiveness in the market. Additionally, input obtained from the evaluation is utilized for further enhancements and development. Therefore, it is anticipated that this research methodology may generate a company profile application that not only fulfills the requirements of Creative Design but also offers substantial benefits in enhancing the firm's service quality and operational efficiency.



Figure 6. Landing Page Page Display



Figure 7. Login Page Display



Figure 8. Dashboard Page View

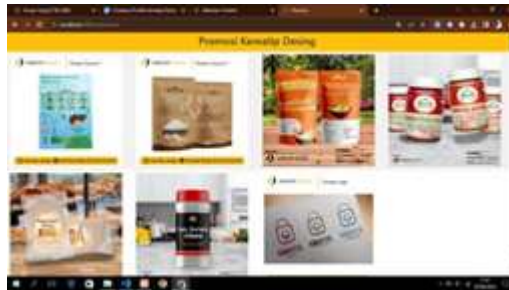

Figure 9. Promotional Page Views

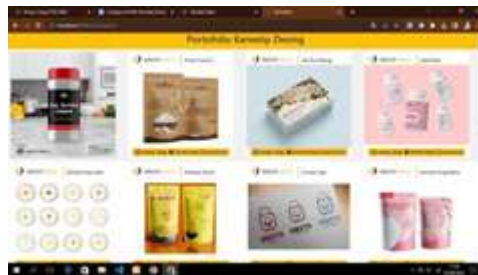

Figure 10. Portfolio Page View



Figure 11. About Us Page View



Figure 12. Message Page View



Figure 13. Admin Dashboard Page Display



Figure 14. Promotion Schedule Page Display



Figure 15. Promotion Update Page Views



Figure 16. Porofolio Udate Page View



Figure 17. Order Number Page View



Figure 18. Promotion Description Page View

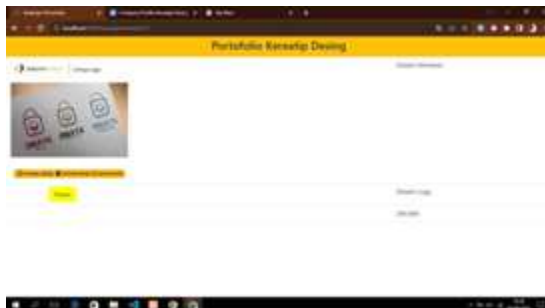

Figure 19. Portfolio Description Page Display



Figure 20. Logout Page Display

Conclusion

The research findings indicate that Creative Design, a design company, is encountering intense competition in the graphic design industry. The utilization of social networks as a means of advertising is currently suboptimal—restricted engagement with prospective clients and web presence.

Multiple recommendations can be utilized as input for creating and constructing applications for a corporate profile, utilizing Laravel as the development framework. The application will enhance online presence, broaden promotional efforts, and augment engagement with prospective customers. This program also enables Creative Design to showcase portfolios.

References

- Amalia, D., Gumilar, R., Utama, Y. S., & Dewi, M. A. (2023, August). Implementation of Extreme Programming in Web Profile Development as an Effective Promotional Media. In 2023 International Conference on Information Management and Technology (ICIMTech) (pp. 649-654). IEEE.
- Amini, M., Rahmani, A., Abedi, M., Hosseini, M., Amini, M., & Amini, M. (2021). Mahamgostar. com as a case study for adoption of laravel framework as the best programming tools for php based web development for small and medium enterprises. *Journal of Innovation & Knowledge*, ISSN, 100-110.
- Kambivi, H., Junirianto, E., & Fadhliyah, N. R. (2020). Development of Inventory Management Application Points of Sale Using Laravel. *Tepian*, 1(1), 9-17.
- Raihan, M., & Negara, E. S. (2023). Expanding Promotion and Marketing of Village Products Through Smart Village System. *PIKSEL: Penelitian Ilmu Komputer Sistem Embedded and Logic*, 11(2), 233-240.
- Nurninawati, E., Effendy, M. Y., & Rianputra, A. M. (2023). Web-Based Product Marketing Information System Design at Definier Store. *International Journal of Cyber and IT Service Management*, 3(1), 1-11.

- Marchiato, C., & Wella, W. (2024). Support System of Quality Control for XYZ Company using PHP Laravel and React Native. *G-Tech: Jurnal Teknologi Terapan*, 8(3), 1370-1378.
- Gibran, C., Dewi, A. R., & Hadinata, E. (2024). Implementasi Framework Laravel Untuk Pengembangan Website Penjualan Ayam Potong Dengan Pemanfaatan Midtrans Menggunakan Metode Fast. *Jurnal Ilmu Komputer Dan Sistem Informasi (JIKOMSI)*, 7(1), 246-253.
- Prasetyo, D., Utami, A., & Laksana, T. G. (2024). Website Based Academic Information System Design Using Extreme Programming Method. *Journal of Informatics Information System Software Engineering and Applications (INISTA)*, 6(2), 134-143.
- Samosir, H., Prasetyo, T. A., Lumbantobing, S., Naibaho, D. O., & Situmorang, C. R. T. (2021, October). Website Development with Laravel and Scrum Method: A Study case of Stasiun Mebel Jepara Store Case. In *2021 17th International Conference on Quality in Research (QIR): International Symposium on Electrical and Computer Engineering* (pp. 60-65). IEEE.
- Christian, Y., & Erline, M. (2021, September). Perancangan dan Penerapan Website Company Profile dan Pemesanan pada PT Ferwendo Karya Pratama. In *Conference on Business, Social Sciences and Technology (CoNeSciNTech)* (Vol. 1, No. 1, pp. 516-523).
- Tjahyadi, S. (2021). Development of QR code-based data sharing web application using system development life cycle method. *Journal of Information System and Technology (JOINT)*, 2(2), 64-73.
- Kumaladewi, N., Iqbal, M. M., & Huda, M. Q. (2022, September). LaravelFramework on Child Friendly Integrated Public Space Management Information System. In *2022 10th International Conference on Cyber and IT Service Management (CITSM)* (pp. 01-05). IEEE.
- Zabidi, A., Ali, M. S. A. M., Yassin, I. M., Tahir, N. M., & Rizman, Z. I. (2022). Analysis of Web Marketplace Integration for E-Suripreneur Multi-Channel Listing Software. *Mathematical Statistician and Engineering Applications*, 71(3s2), 905-914.
- Wini, W. I. S. L., Siregar, H. F., & Simargolang, M. Y. (2024). Design of Information System for Application for Employee Promotion in the Ministry of Religion of Medan City. *Bigint Computing Journal*, 2(1), 23-33.
- Usanto, U., Nurlaela, L., Sopian, A., & Alfiah, F. (2023). Umrah Registration System Using Extreme Programming Method Towards Worship

Tourism. *International Journal of Cyber and IT Service Management*, 3(1), 22-31.

Rabiah, N. N., Lindawati, L., & Sarjana, S. (2022). Web-Based Laboratory Inventory Application Using QR Code and RFID in Telecommunication Engineering Laboratories/Workshops. *Sinkron: jurnal dan penelitian teknik informatika*, 6(4), 2248-2261.

Tiana, W., & Nopriandi, H. (2023). Design and Construction of a Transaction System for the Manggis Mandiri Building Store in Teluk Kuantan. *Jurnal Teknologi dan Open Source*, 6(2), 178-189.